



- Reduced Wear
- Energy Efficient
- Minimized Maintenance
- Decreased Downtime
- Seamless Integration
- Fully Customizable
- Compact Design

The MiniDenseveyor® is a low velocity dense phase conveying system that has been developed for small transfer capacity requirements. Modelled on the well-established Denseveyor® the smaller size allows installation flexibility and the use of a cast vessel provides exceptional savings and extremely long equipment life. Operating economy is achieved from very low conveying air requirements and maintenance free operation. The only moving part in the system is our proprietary Dome Valve®. It is capable of operating one million cycles between inspections and exceeds the performance of most other valves where continuous service with abrasive materials and a reliable pressure differential is required. The MiniDenseveyor® is fully assembled and tested and requires only connection to the conveying pipeline and the operating utilities.

- Temperature rating up to 650°F
- Pressure rating up to 100psig (7barg)
- Standard material cast iron A278
- Available in 304/316 stainless steel
- Industrial coatings such as Teflon®, tungsten carbide, nickel, and others
- Fully assembled and tested prior to shipment
- Manufactured in Maryville, TN USA
- Global customer support for service and spare parts
- ISO 9001:2015 Certified

UK – Macawber UK Ltd.
 India – Macawber Engineering Systems India, Ltd. Pvt.

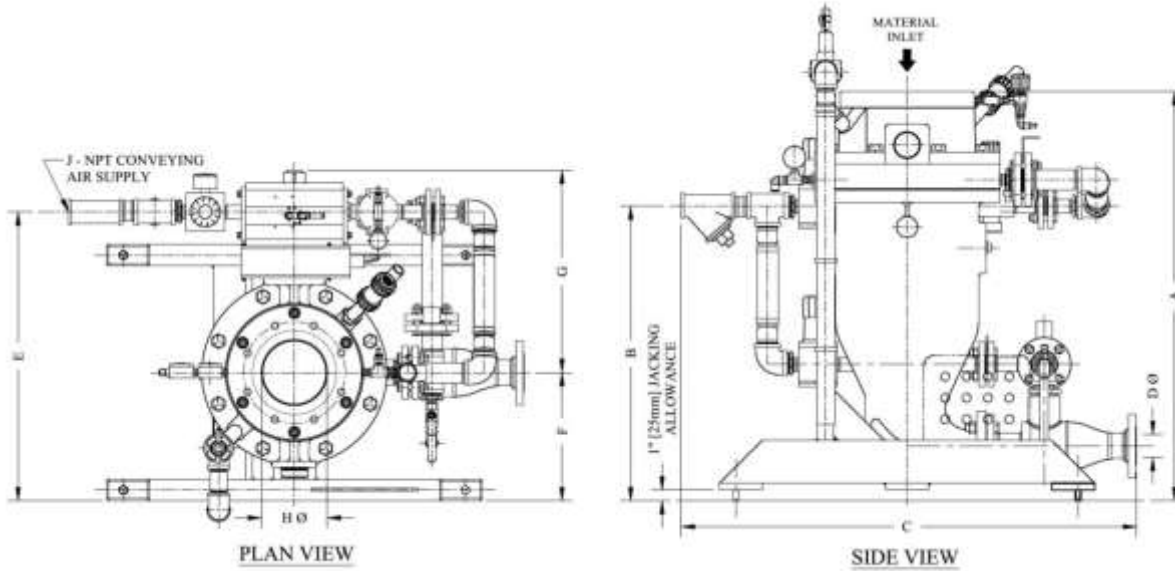

MODEL	DIMENSIONS (INCH)									NET WT (LBS)
	A	B	C	D	E	F	G	H	J	
15/4-2	28 7/8"	29 7/16"	47 1/8"	1: 1 1/2": 2"	28 13/16"	13 3/16"	19 3/16"	4 1/8"	1 1/2"	296
30/4-2	39 5/16"	14 15/16"	45 9/16"	1 1/2": 2"	24 7/16"	11"	17"	4 1/8"	1 1/2"	345
30/6-2	38 5/16"	27 5/8"	42 5/8"	1 1/2": 2"	29"	13 15/16"	18 15/16"	6 3/16"	1 1/2"	386
60/4-2	38 5/16"	24 15/16"	50 9/16"	2"	28 15/16"	13 3/16"	18 15/16"	4"	1 1/2"	1038
60/6-2	38 5/16"	34 15/16"	50 9/16"	2"	28 15/16"	13 3/16"	18 3/4"	6 3/16"	1 1/2"	1076
85/8-3	47 1/4"	30 3/8"	50 11/16"	3"	28 13/16"	13 3/16"	21 5/16"	8 1/16"	1 1/2"	1121

INFORMATION NOT CERTIFIED FOR INSTALLATION PURPOSES

UK – Macawber UK Ltd.
 India – Macawber Engineering Systems India, Ltd. Pvt.