



Reduced Wear
Energy Efficient
Minimized Maintenance
Decreased Downtime
Seamless Integration
Fully Customizable
Fully Enclosed Convey Process
Low Profile

The Sandpump® is a low velocity dense phase pneumatic conveying system specifically designed for the foundry industry for the purpose of conveying sand, silica sand, reclaimed silica sand, and ceramic beads commonly found in the casting and foundry industries. Compact in design and low-profile, the Sandpump® has the ability to be positioned below shakeout tables and reclaimers for a seamless integration into existing process layouts. Fitted with our robust Dome Valve® its unique design provides efficiencies in wear reduction, air consumption, and reduce maintenance downtime.

- Temperature rating up to $\leq 650^{\circ}\text{F}$ (343°C). Higher temperature ratings available
- Standard pressure rating up to 100 psig. Higher pressure ratings available
- Standard material 516 Gd70 carbon steel
- Available in 304/316 stainless steel, aluminum, galvanized, and others
- Industrial coatings such as Teflon®, tungsten carbide, nickel, and others
- Fully assembled and tested prior to shipment
- Global customer support for service and spare parts
- Manufactured in Maryville, TN USA
- ISO 9001:2015 Certified

UK – Mactenn Systems, Ltd.

India – Macawber Engineering Systems India, Ltd. Pvt.

China – Macawber China

Macawber Engineering, Inc



Advanced Pneumatic Conveying Systems
Controlled Injection Systems
Inflatable Seat Valve
Process Engineering

ISO 9001 Registered | ASME Certified

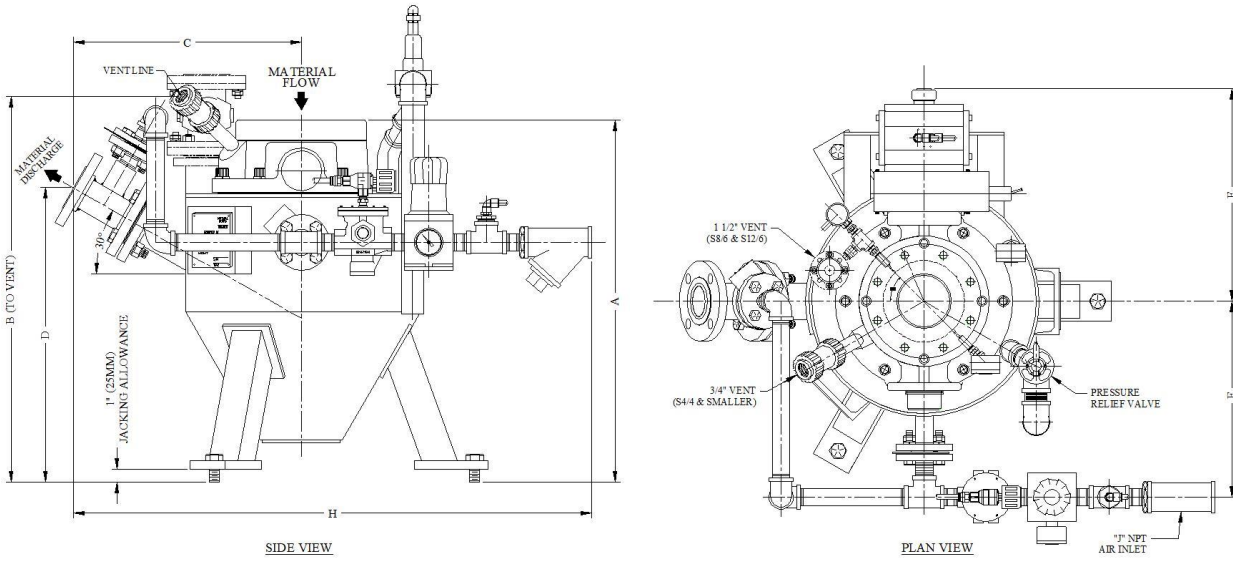

MODEL	DIMENSIONS (INCH)										NET WT (LBS)
	A	B	C	D	E	F	G	H	J	K	
S2/4-2	27-1/16"	30 5/8"	17"	22-1/16"	16"	14-5/8"	4"	36-3/4"	1-1/2"	2"	318
S3/4-3	34-3/16"	37 3/4"	20-3/16"	26-3/16"	15-15/16"	16-1/4"	4"	41-15/16"	1-1/2"	3"	417
S4/4-4	40-1/8"	43 11/16"	23-5/16"	32"	16-7/8"	18-3/8"	4"	42-5/8"	1-1/2"	4"	610
S8/6-5	46 7/16"	49-11/16"	28-3/8"	37-1/8"	20-1/16"	21-9/16"	6"	54-1/2"	2"	5"	925
S12/6-6	57-15/16"	61-3/16"	28-9/16"	38-3/4"	20-1/2"	22-3/16"	6"	54-11/16"	2"	6"	945

INFORMATION NOT CERTIFIED FOR INSTALLATION PURPOSES

UK – Mactenn Systems, Ltd.
India – Macawber Engineering Systems India, Ltd. Pvt.
China – Macawber China

www.macawber.com
sales@macawber.com

1829 Clydesdale Street,
Maryville, TN 37801 USA

Phone: +1 (865) 984-5286
Fax: +1 (865) 977-4131

Equipment Specification | SANDPUMP® 1-04