



Extreme Reliability for Severe Applications

Minimal Maintenance

Decreased Downtime

Seamless Integration

Fully Customizable

The Double Dump Valve® is the incorporation of two Macawber Dome Valves®. The intent of this valve is to replace a double flap valve or rotary valve. The top Dome Valve® is sized for the inlet dimension which the bottom valve is sized for the outlet diameter of the downstream equipment. An accumulating chamber is specifically sized between the valves and is specified for the process parameters. If pressure either upstream or downstream is present, the spool piece will, in turn, also be pressured and monitored with a pressure transducer to match the given pressure measurement. These applications are generally low pressure (vacuum) applications.

- Standard temperature rating up to < 650°F (345°C)
- Customizable temperature rating up to < 1850°F (1010°C)
- Standard pressure rating up to <100 psig (6.9 barg)
- Customizable pressure rating up to <400 psig (28 barg)
- Designs available from 1 inch to 30 inches
- Standard material A278 cast iron
- Available in 304/316 stainless steel, aluminum, galvanized, and others
- Food grade, FDA, and pharmaceutical finishes
- Industrial coatings such as PTFE, tungsten carbide, nickel, ferrite nitride carbonization, and others
- Elastomer options neoprene, silicone, Viton, EPDM, FDA rubber
- Highly customizable
- Fully assembled and tested prior to shipment
- Manufactured in Maryville, TN USA
- Global customer support for service and spare parts
- ISO 9001:2015 Certified

UK – Macawber UK Ltd.

India – Macawber Engineering Systems India, Ltd. Pvt.

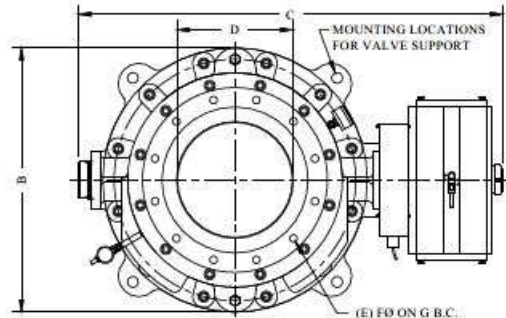

PLAN VIEW

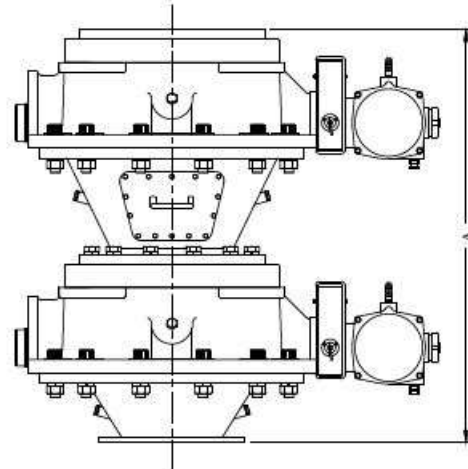

FRONT VIEW

MODEL	DIMENSIONS (INCH)							NET WT (LBS)
	A	B	C	D	E	F	G	
12"	42 1/2"	27 3/16"	43 1/2"	11 13/16"	12	7/8"	17"	1684

Available in 2" – 30". Contact Macawber for details.

**INFORMATION NOT CERTIFIED FOR INSTALLATION PURPOSES**

UK – Macawber UK Ltd.  
 India – Macawber Engineering Systems India, Ltd. Pvt.